

# The Current-Mode Story

How current-mode was created,  
how it changed, and how it is disappearing again.

Hanspeter Schmid

Institute of Microelectronics (IME)  
University of Applied Sciences Northwestern Switzerland (FHNW)  
Contact by E-Mail: [hanspeter.schmid@fhnw.ch](mailto:hanspeter.schmid@fhnw.ch)

IEEE CAS Distinguished Lecturer Program — Talk 1  
ETH Zürich, March 1, 2011.

## University of **Applied** Sciences:

- Switzerland's apprenticeship system
- two kinds of universities in Switzerland;
- MSE as apprentice/master teams
- different thinking style; altered state of mind.

[2/2]

## Current-Mode Story

HP Schmid

## Introduction

## Creation

Translinear Loop

## Tenacity

Conveyors

CFB Opamps

Universal AE

## Rigidification

Blindness

Contradictions

## Extinction?

Is it better?

Destruction

Vision

## Hindsight

## Conclusions

Thinking Styles

Publications

Comment on Hanspeter's 2003  
Current-Mode paper  
[Schmid 03]:

*Aghhh. . . I've read it. Are some  
herbs already legalized in  
Switzerland?*

[Adam Jankiewicz,  
July 2009, diyaudio.com]





Found through the log file of my web server

- You may think the same after this talk
- In the future, you'll say "is this real or just a bad case of Swiss herbs?"
- Inside jokes
- How long does it takes to explain this to someone else?
- Ludwik Fleck: Thinking Style = altered state of mind!
- Doing science works exactly like this.
- Scientific facts are almost precisely the same as inside jokes.
- Some of these jokes have got lame with time.

Current-Mode  
Story

HP Schmid

## Introduction

## Creation

Translinear Loop

## Tenacity

Conveyors

CFB Opamps

Universal AE

## Rigidification

Blindness

Contradictions

## Extinction?

Is it better?

Destruction

Vision

## Hindsight

## Conclusions

Thinking Styles

Publications

Taken from the first six papers on **IEEE**Xplore on “current-mode filters” (December 2010):

- higher bandwidth
- simpler architecture
- better dynamic range
- operates at lower voltage
- better linearity
- lower power consumption

References:

- *Analog IC design: The current-mode approach* (eds. Toumazou/Lidgey/Haigh, 1990)
- “All current-mode frequency selective circuits” (Electronics Letters, Roberts/Sedra, 1989)

# Current-Mode Story

## └ Introduction

### └ Why current-mode *must* be good

#### Why current-mode *must* be good

Taken from the first six papers on IEEE Xplore on "current-mode filters" (December 2010):

- higher bandwidth
- simpler architecture
- better dynamic range
- operates at lower voltage
- better linearity
- lower power consumption

#### References:

- *Analog IC design: The current-mode approach* (eds. Toumazou/Lidgey/Haigh, 1990)
- "All current-mode frequency selective circuits" (Electronics Letters, Roberts/Sedra, 1989)

## Quick paper search:

- Two papers give *no reference at all*. Three give the "Analog IC design: The current-mode approach"
- One gives an Electronics Letter by Roberts and Sedra
- None gives proofs!
- During PhD: Tree search done, 70 papers, no proofs found.
- What I found are "conclusions upgrades" like the following: [2/7]

Current-Mode  
Story

HP Schmid

## Introduction

## Creation

Translinear Loop

## Tenacity

Conveyors

CFB Opamps

Universal AE

## Rigidification

Blindness

Contradictions

## Extinction?

Is it better?

Destruction

Vision

## Hindsight

## Conclusions

Thinking Styles

Publications

**Kumngern10** At present, the design and implementation of current-mode active filters using second-generation current conveyors (CCII)s have received considerable attention owing to the fact that **their bandwidth, linearity, simple circuitry, low power consumption and dynamic range performances are better** than those of their operational amplifier (op-amp) based counterparts.

**Roberts89** In this letter a new method for performing analogue signal filtering has been proposed. By exploiting the interreciprocal property of linear networks, voltage-amplifier filter circuits can be converted to equivalent current-amplifier filter circuits with identical sensitivity properties. However, **higher bandwidths, greater linearity and wider dynamic range are expected** from these current-mode filtering circuits.

**Kumngern10** At present, the design and implementation of current-mode active filters using second-generation current conveyors (CCII)s have received considerable attention owing to the fact that **their bandwidth, linearity, simple circuitry, low power consumption and dynamic range performances are better** than those of their operational amplifier (op-amp) based counterparts.

**Roberts89** In this letter a new method for performing analogue signal filtering has been proposed. By exploiting the interreciprocal property of linear networks, voltage-amplifier filter circuits can be converted to equivalent current-amplifier filter circuits with identical sensitivity properties. However, **higher bandwidths, greater linearity and wider dynamic range are expected** from these current-mode filtering circuits.

Kumngern takes Roberts's Expectation as a proof!

- I Ging: “Persistence brings good fortune”
- Tenacity is necessary for some time, otherwise you give up too soon
  - don't stick to it too long, or you only see what you want to see.
  - Today: current-mode as an example.

[1/8]

Current-Mode  
Story

- 1 Introduction
- 2 Where does current-mode come from?

HP Schmid

Gilbert's translinear loop

Introduction

- 3 Tenacity

Current Conveyors

Creation

Current-Feedback Opamps (CFB Opamps)

Translinear Loop

Universal Active Element

Tenacity

- 4 Rigidification

Conveyors

Complete Blindness

CFB Opamps

Dealing with contradictions

Universal AE

Rigidification

- 5 Extinction?

Blindness

Now: which one is better?

Contradictions

Extinction?

Attempts to break open the thinking style

Is it better?

What is behind the vision?

Destruction

Vision

Hindsight

- 6 Stuck in Style and Hindsight

Conclusions

- 7 Conclusions

Thinking Styles

Thinking Styles (after Ludwik Fleck)

Publications

Different types of publications

So I go with you through a thinking style:

- how it comes into existence
- how it gets stronger
- how it gets rigid to the point of becoming dangerous
- and what happens then . . .

→ First we start with researchers in the mist.

[1/9]

Current-Mode  
Story

HP Schmid

## Introduction

## Creation

Translinear Loop

## Tenacity

Conveyors  
CFB Opamps  
Universal AE

## Rigidification

Blindness  
Contradictions

## Extinction?

Is it better?  
Destruction  
Vision

## Hindsight

## Conclusions

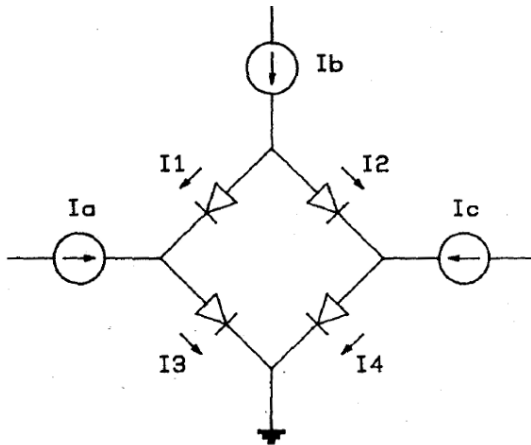
Thinking Styles  
Publications

From "Current-mode Circuits From A Translinear Viewpoint: A Tutorial"  
Barrie Gilbert in [Toumazou 90]

## Current-Mode Story

- └ Where does current-mode come from?
  - └ Gilbert's translinear loop
    - └ Gilbert's translinear loop

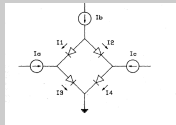

From "Current-mode Circuits From A Translinear Viewpoint: A Tutorial"  
Barrie Gilbert in [Tommaso 90]

*(Slide timing!)*

Tackling a difficult problem is like walking in the mist

– Suddenly, you see a path

→ Go far enough down the path to see where it leads.

– Gilbert's example: how can you calculate the diode currents?

[1/10]

Current-Mode  
Story

HP Schmid

## Introduction

## Creation

Translinear Loop

## Tenacity

Conveyors  
CFB Opamps  
Universal AE

## Rigidification

Blindness  
Contradictions

## Extinction?

Is it better?  
Destruction  
Vision

## Hindsight

## Conclusions

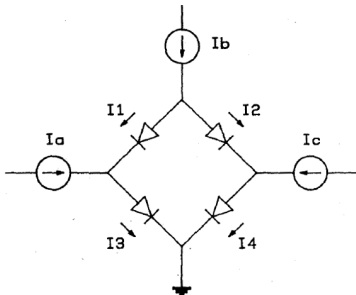
Thinking Styles  
Publications

Emitter Current Density:  $J_i = \frac{I_i}{A_i}$

$$\longrightarrow J_1 J_4 = J_2 J_3 .$$

## Current-Mode Story

- └ Where does current-mode come from?
  - └ Gilbert's translinear loop
  - └ Gilbert's translinear loop

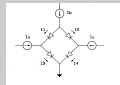

Emitter Current Density:  $J_i = \frac{I_i}{A_i}$

$$\rightarrow J_1 J_3 = J_2 J_4$$

Barrie Gilbert's words: In a closed loop containing an even number of forward biased junctions, arranged so that there are an equal number of clockwise-facing and counterclockwise-facing polarities, the product of the current densities in the clockwise direction is equal to the product of the current densities in the counter clockwise direction.

→ Example:

[1/11]

Current-Mode  
Story

HP Schmid

Introduction

Creation

Translinear Loop

Tenacity

Conveyors

CFB Opamps

Universal AE

Rigidification

Blindness

Contradictions

Extinction?

Is it better?

Destruction

Vision

Hindsight

Conclusions

Thinking Styles

Publications

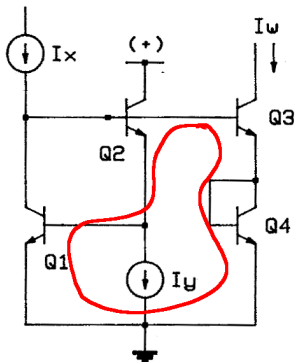

$$J_1 J_2 = J_3 J_4 \xrightarrow{\text{same size}} I_1 I_2 = I_3 I_4$$

$$\rightarrow I_x I_y = I_w^2 \rightarrow I_w = \sqrt{I_x I_y}$$

## Current-Mode Story

- └ Where does current-mode come from?
  - └ Gilbert's translinear loop
    - └ Example: Square-Root Circuit



$$I_{D1} I_{D2} = I_{D2} I_{D3} \quad \text{same area} \quad I_{D1} I_{D2} = I_{D2} I_{D3}$$

$$\rightarrow I_{D1} I_2 = I_2^2 \quad \rightarrow I_2 = \sqrt{I_{D1} I_2}$$

The diode voltages are not necessary to be discussed if you want to understand this structure

- “Current Mode”!
- Lots of circuits can be understood like this
- Now we see a path through the fog
  - Let’s see how far it will get us, and what we find along the way!
  - Persistence; Tenacity.
- The first thing we meet along the way are current conveyors. [2/13]

A general block that is useful to process currents xCCyz:

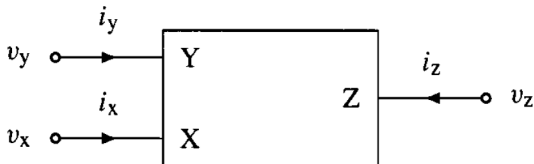

$$\text{CCII-} \quad i_y \leftarrow 0, \quad v_x \leftarrow v_y, \quad i_z \leftarrow -i_x .$$

$$\text{CCII+} \quad i_y \leftarrow 0, \quad v_x \leftarrow v_y, \quad i_z \leftarrow +i_x .$$

$$\text{CCI}\pm \quad i_y \leftarrow i_x, \quad v_x \leftarrow v_y, \quad i_z \leftarrow \pm i_x .$$

$$\text{CCIII}\pm \quad i_y \leftarrow -i_x, \quad v_x \leftarrow v_y, \quad i_z \leftarrow \pm i_x .$$

$$\text{VICCII-} \quad i_y \leftarrow 0, \quad v_x \leftarrow -v_y, \quad i_z \leftarrow -i_x .$$

## Current-Mode Story

└ Tenacity

└ Current Conveyors

└ A family of current conveyors

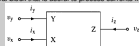
A general block that is useful to process currents  $xCCyz$ :

CCII- :  $i_Y \leftarrow 0, v_X \leftarrow v_Y, i_Z \leftarrow -i_X$

CCII+ :  $i_Y \leftarrow 0, v_X \leftarrow v_Y, i_Z \leftarrow +i_X$

CCI :  $i_Y \leftarrow i_X, v_X \leftarrow v_Y, i_Z \leftarrow \pm i_X$

CCIII :  $i_Y \leftarrow -i_X, v_X \leftarrow v_Y, i_Z \leftarrow \pm i_X$

VICCII- :  $i_Y \leftarrow 0, v_X \leftarrow -v_Y, i_Z \leftarrow -i_X$

*(Slide timing!)*

Current conveyors are a kind of bidirectional current mirrors

- explain CCII– including  $\leftarrow$  and port impedances
- CCII+ with opposite current sign
- CCI with current source at input Y
- CCIII Y current with opposite sign (new name really necessary?)
- VICC inverting voltage buffer

[2/15]

Current-Mode  
Story

HP Schmid

Introduction

Creation

Translinear Loop

Tenacity

Conveyors

CFB Opamps

Universal AE

Rigidification

Blindness

Contradictions

Extinction?

Is it better?

Destruction

Vision

Hindsight

Conclusions

Thinking Styles

Publications

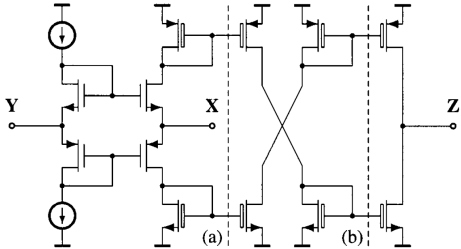
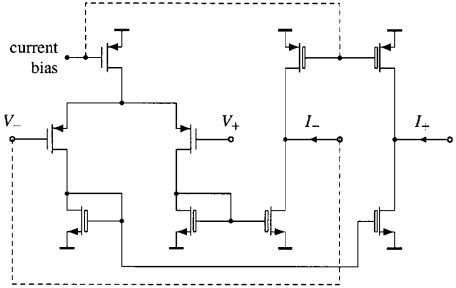

## Current-Mode Story

└ Tenacity

└ Current Conveyors

└ CMOS Current Conveyors (CCII±)

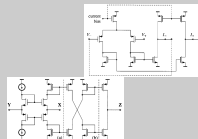

First structure: OTA with feedback

- Second structure more typical (no feedback): explain details
- it is simple to make non-unity gain
- a lot more different implementations around!
- large number of papers: all kinds of functions with CCs
- one famous circuit is the current-feedback opamp

[3/18]

Current-Mode  
Story

HP Schmid

Introduction

Creation

Translinear Loop

Tenacity

Conveyors

CFB Opamps

Universal AE

Rigidification

Blindness

Contradictions

Extinction?

Is it better?

Destruction

Vision

Hindsight

Conclusions

Thinking Styles

Publications

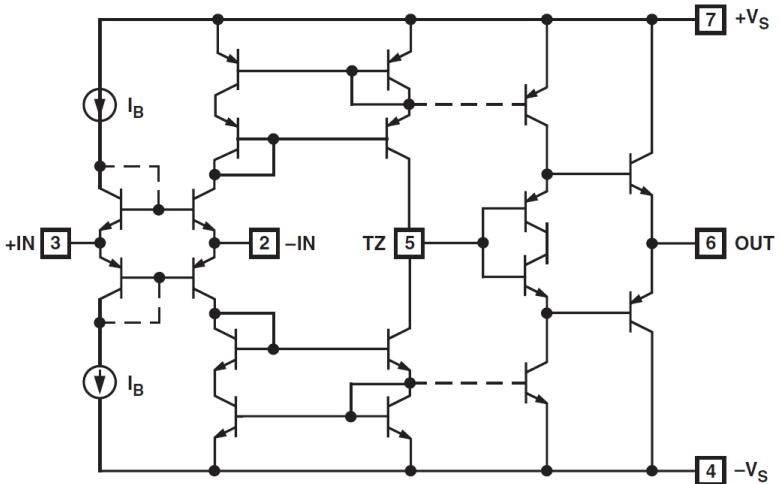

## Current-Mode Story

└ Tenacity

└ Current-Feedback Opamps (CFB Opamps)

└ Current-Feedback Opamps: The AD844

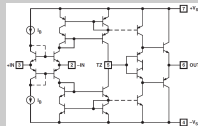

Function:  $IN+$  to  $IN-$ : voltage buffer

- Current into  $IN-$  copied to  $Z$
- $Z$  to  $OUT$ : voltage buffer
- $CCII+$  and voltage buffer in one IC.

Current-Mode  
Story

HP Schmid

Introduction

Creation

Translinear Loop

Tenacity

Conveyors

CFB Opamps

Universal AE

Rigidification

Blindness

Contradictions

Extinction?

Is it better?

Destruction

Vision

Hindsight

Conclusions

Thinking Styles

Publications

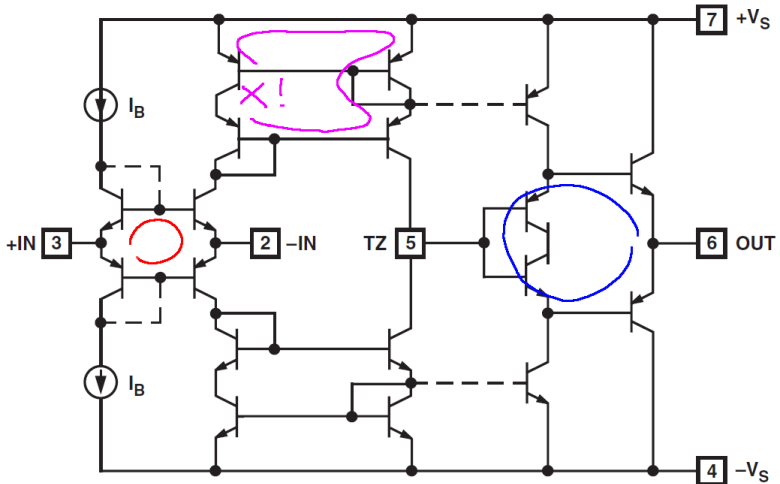



Current-Mode Story

HP Schmid

Introduction

Creation

Translinear Loop

Tenacity

Conveyors

CFB Opamps

Universal AE

Rigidification

Blindness

Contradictions

Extinction?

Is it better?

Destruction

Vision

Hindsight

Conclusions

Thinking Styles

Publications

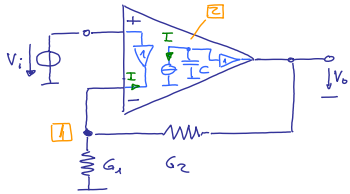
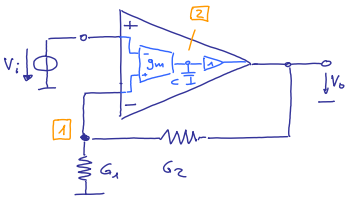

$$\frac{V_o}{V_i} = \frac{g_m/sC}{1 + g_m/sC \cdot \frac{G_2}{G_1 + G_2}} = \frac{(G_1 + G_2) \cdot g_m/sC}{(G_1 + G_2) + G_2 g_m/sC}$$

$$\frac{V_o}{V_i} = \frac{(G_1 + G_2)/sC}{1 + G_2/sC} = \frac{G_1 + G_2}{sC + G_2}$$

$$A_{DC} = \frac{G_1 + G_2}{G_2} \quad BW = \frac{G_2}{G_1 + G_2} \cdot \frac{g_m}{C}$$

$$A_{DC} = \frac{G_1 + G_2}{G_2} \quad BW = \frac{G_2}{C}$$

$$\Rightarrow A_{DC} \cdot BW = GBWP = \frac{g_m}{C}$$

$$\Rightarrow A_{DC} \cdot BW = GBWP = \frac{G_1 + G_2}{C}$$

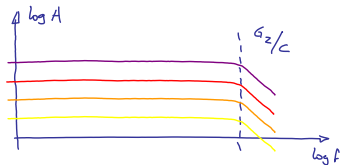
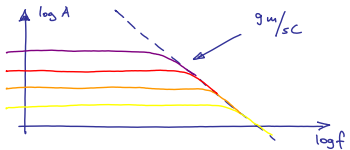

## Current-Mode Story

Tenacity

Current-Feedback Opamps (CFB Opamps)

CFB Opamp and Gain-Bandwidth Product

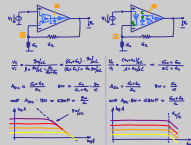
*(Slide timing!)*

This circuit has constant bandwidth instead of constant gain-bandwidth product! Useful for xDSL line drivers.

- explain normal OpAmp with resistive feedback
- explain CFB circuit
- limit of the gain: input resistance at IN–
- very good for xDSL line drivers (e.g., AD8016)
- OPA860 and AD844 can be used as CCII+
- appear a lot in CM literature
- Example for your lab table:

Current-Mode  
Story

HP Schmid

Introduction

Creation

Translinear Loop

Tenacity

Conveyors

CFB Opamps

Universal AE

Rigidification

Blindness

Contradictions

Extinction?

Is it better?

Destruction

Vision

Hindsight

Conclusions

Thinking Styles

Publications

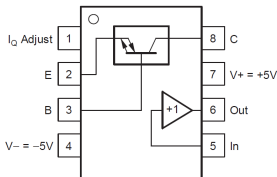
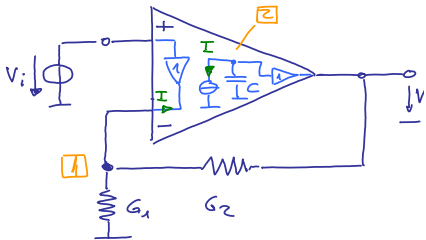

## Current generator for the lab table:

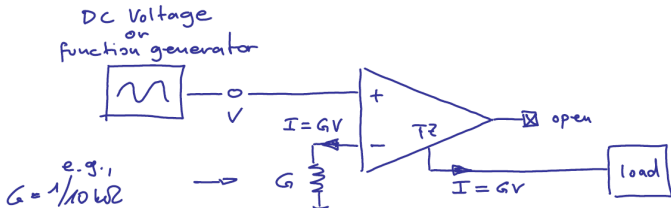

## Current-Mode Story

- Tenacity

- Current-Feedback Opamps (CFB Opamps)

- Buy a CCII+: OPA860 (or AD844)

Buy a CCII+: OPA860 (or AD844)

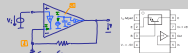

Current generator for the lab table:

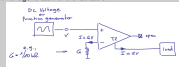

Very simple to build quickly

- Stable! (no feedback)

- In literature: a huge number of CCII circuits; CCII is *super!*

→ *Any* linear or nonlinear function can be implemented with CCII's and passive elements.

[2/26]

Current-Mode  
Story

HP Schmid

Introduction

Creation

Translinear Loop

Tenacity

Conveyors

CFB Opamps

Universal AE

Rigidification

Blindness

Contradictions

Extinction?

Is it better?

Destruction

Vision

Hindsight

Conclusions

Thinking Styles

Publications

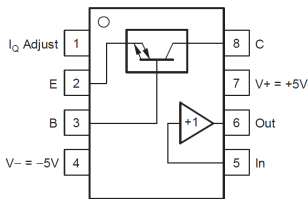
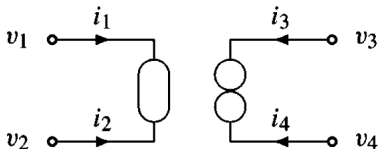
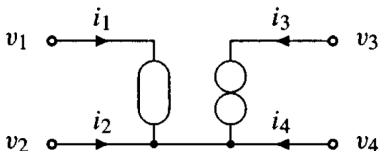

Amplificateur idéal  
(Tellegen)

$$\begin{bmatrix} v_a \\ i_a \end{bmatrix} = \begin{bmatrix} 0 & 0 \\ 0 & 0 \end{bmatrix} \cdot \begin{bmatrix} v_b \\ -i_b \end{bmatrix}$$

## Current-Mode Story

Tenacity

Universal Active Element

Universal Active Element

## Universal Active Element

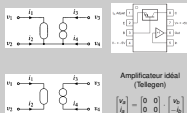
*(Slide timing!)*

Universal Active Element: “Set of Spice Elements”

- Explain Nullor; Golden opamp rules
- Carlin defined two nullors: 3T- and 4T-Nullor
- Tellegen had only one element.
- Big difference: Tellegen described a 2-port, Carlin a 4-terminal
- CCII<sub>+</sub> in OPA860, but CCII<sub>−</sub> = Three-Terminal Nullor. [3/29]

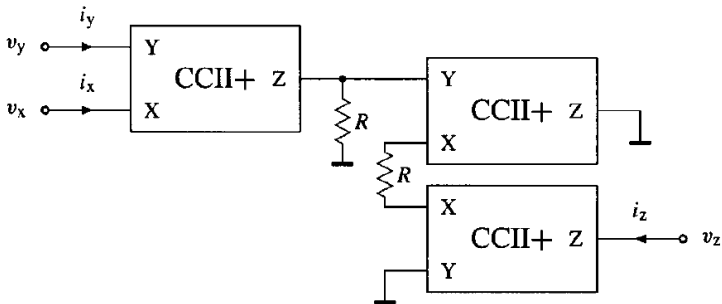

Fig. 5. CCII<sup>-</sup> built using three CCII<sup>+</sup> and two resistors.



Current-Mode  
Story

HP Schmid

Introduction

Creation

Translinear Loop

Tenacity

Conveyors  
CFB Opamps  
Universal AE

Rigidification

Blindness

Contradictions

Extinction?

Is it better?  
Destruction  
Vision

Hindsight

Conclusions

Thinking Styles  
Publications

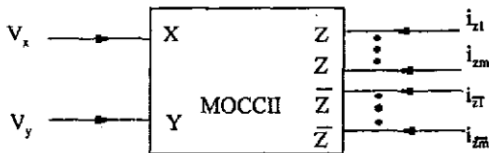
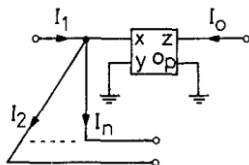
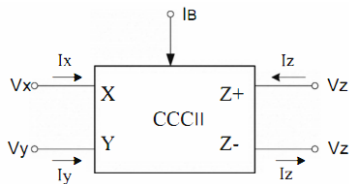

## Current-Mode Story

└ Rigidification

└ Complete Blindness

└ Partial Blindness: Conveyor Galore ...

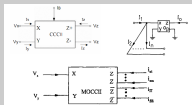
*(Slide timing!)*

Rigidity: Thinking constraints become self-sufficient thinking necessities:

→ “Current Conveyor Versatility”: more, more, more!!!

– lots of papers stopping at the block level, no real circuits

– if real circuit: often trivially slow, with almost ideal curves.

– at least it may work. There are examples for complete blindness, though:

[1/34]

Current-Mode  
Story

HP Schmid

Introduction

Creation

Translinear Loop

Tenacity

Conveyors

CFB Opamps

Universal AE

Rigidification

Blindness

Contradictions

Extinction?

Is it better?

Destruction

Vision

Hindsight

Conclusions

Thinking Styles

Publications

Transfer function			Admittance				
$I_{02}/I_{in}$	$I_{05}/I_{in}$		$y_1$	$y_2$	$y_3$	$y_4$	$y_5$
1	BP	HP	$1/R_1$	$1/R_2$	$sC_3$	0	$sC_5$
2	HP	BP	$1/R_1$	$sC_2$	$sC_3$	0	$1/R_5$
3	LP	BP	$sC_1$	$1/R_2$	$1/R_3$	0	$sC_5$
4	BP	LP	$sC_1$	$sC_2$	$1/R_3$	0	$1/R_5$
5	BP	HP	$sC_1 + 1/R_1$	$1/R_2$	0	$sC_4$	$sC_5$
6	HP	BP	$sC_1 + 1/R_1$	$sC_2$	0	$sC_4$	$1/R_5$
7	LP	BP	$sC_1 + 1/R_1$	$1/R_2$	0	$1/R_4$	$sC_5$
8	BP	LP	$sC_1 + 1/R_1$	$sC_2$	0	$1/R_4$	$1/R_5$

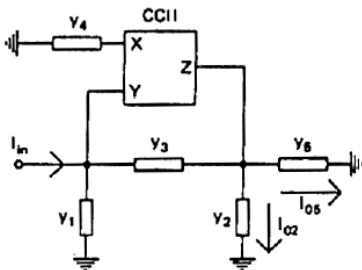

## Current-Mode Story

Rigidification

Complete Blindness

Blindness: 8 Filters; how many work?

Transfer function		Architecture					
$A_{in}/A_{out}$	$f_{cut}/f_c$	$\beta_1$	$\beta_2$	$\beta_3$	$\beta_4$	$\beta_5$	
1 BP	HP	$1/R_1$	$1/R_2$	$\alpha C_1$	0	$\alpha C_2$	
2 DSP	BP	$1/R_1$	$\alpha C_1$	$\alpha C_2$	0	$1/R_2$	
3 LP	BP	$\alpha C_1$	$1/R_2$	$1/R_1$	0	$\alpha C_2$	
4 BP	LP	$\alpha C_1$	$\alpha C_2$	$1/R_2$	0	$1/R_1$	
5 BP	HP	$\alpha C_1 + 1/R_1$	$1/R_2$	0	$\alpha C_2$	$\alpha C_1$	
6 HP	BP	$\alpha C_1 + 1/R_1$	$\alpha C_2$	0	$\alpha C_1$	$1/R_2$	
7 LP	BP	$\alpha C_1 + 1/R_1$	$1/R_2$	0	$1/R_1$	$\alpha C_2$	
8 BP	LP	$\alpha C_1 + 1/R_1$	$\alpha C_2$	0	$1/R_2$	$1/R_1$	

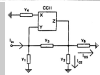

Example for complete blindness:

– CCII sigle-amplifier biquad, 8 configurations.

– How many of them work?

→ four: CCII switched off!

→ four: feedback loop cut open!

→ None of these filters can make complex poles! How could the reviewers possibly miss this?

– Rigidity of a thinking style may be softer

→ two degrees of dealing with contradictions:

[2/36]

Transfer function			Admittance				
$I_{02}/I_{in}$	$I_{05}/I_{in}$		$y_1$	$y_2$	$y_3$	$y_4$	$y_5$
1	BP	HP	$1/R_1$	$1/R_2$	$sC_3$	0	$sC_5$
2	HP	BP	$1/R_1$	$sC_2$	$sC_3$	0	$1/R_5$
3	LP	BP	$sC_1$	$1/R_2$	$1/R_3$	0	$sC_5$
4	BP	LP	$sC_1$	$sC_2$	$1/R_3$	0	$1/R_5$
5	BP	HP	$sC_1 + 1/R_1$	$1/R_2$	0	$sC_4$	$sC_5$
6	HP	BP	$sC_1 + 1/R_1$	$sC_2$	0	$sC_4$	$1/R_5$
7	LP	BP	$sC_1 + 1/R_1$	$1/R_2$	0	$1/R_4$	$sC_5$
8	BP	LP	$sC_1 + 1/R_1$	$sC_2$	0	$1/R_4$	$1/R_5$

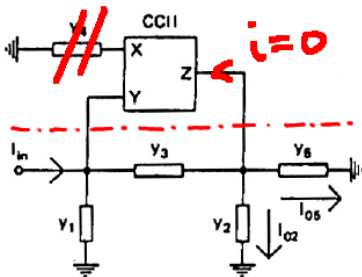

Current-Mode  
Story

HP Schmid

Introduction

Creation

Translinear Loop

Tenacity

Conveyors

CFB Opamps

Universal AE

Rigidification

Blindness

Contradictions

Extinction?

Is it better?

Destruction

Vision

Hindsight

Conclusions

Thinking Styles

Publications

	Transfer function		Admittance				
	$I_{02}/I_{in}$	$I_{05}/I_{in}$	$y_1$	$y_2$	$y_3$	$y_4$	$y_5$
1	BP	HP	$1/R_1$	$1/R_2$	$sC_3$	0	$sC_5$
2	HP	BP	$1/R_1$	$sC_2$	$sC_3$	0	$1/R_5$
3	LP	BP	$sC_1$	$1/R_2$	$1/R_3$	0	$sC_5$
4	BP	LP	$sC_1$	$sC_2$	$1/R_3$	0	$1/R_5$
5	BP	HP	$sC_1 + 1/R_1$	$1/R_2$	0	$sC_4$	$sC_5$
6	HP	BP	$sC_1 + 1/R_1$	$sC_2$	0	$sC_4$	$1/R_5$
7	LP	BP	$sC_1 + 1/R_1$	$1/R_2$	0	$1/R_4$	$sC_5$
8	BP	LP	$sC_1 + 1/R_1$	$sC_2$	0	$1/R_4$	$1/R_5$

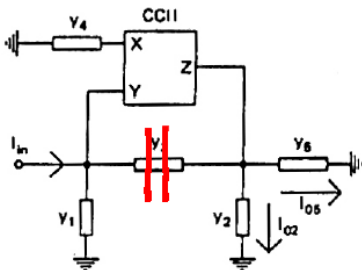



## Current-Mode Story

Rigidification

Dealing with contradictions

CFB Opamp: Universal active element?

CFB Opamp: Universal active element?

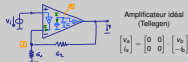
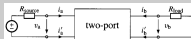
Two-port configuration:  $i_2 = \xi_2$  and  $i_1 = \xi_1$  forced!

Tellegen's ideal amplifier set: VCVS, COCS, VCCS, CCVS.

One way of dealing with contradictions is to declare them not to be contradicting, sometimes with great effort. — CFB does not fit. The all-zero chain matrix just describes the "what" (Golden opamp rules)

- Using anything as a two-port forces current constraints on the circuit!
- four ideal amplifiers: 4 controlled sources, with infinite gain
- unfortunately, the CFB opamp does not work in that configuration
- It obviously is a universal active element; so what do we do?

[3/39]

Current-Mode  
Story

HP Schmid

Introduction

Creation

Translinear Loop

Tenacity

Conveyors

CFB Opamps

Universal AE

Rigidification

Blindness

Contradictions

Extinction?

Is it better?

Destruction

Vision

Hindsight

Conclusions

Thinking Styles

Publications

Payne 96: *The architecture of this device comprises a transresistance op-amp (CCVS) with an additional input voltage-follower (VF)*

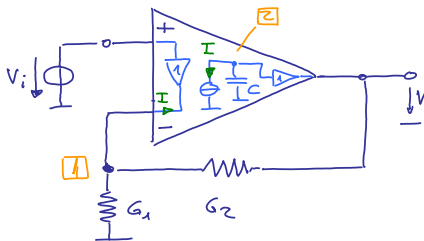
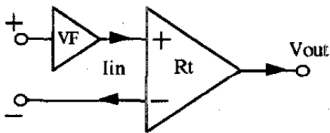

## Current-Mode Story

- └ Rigidification

- └ Dealing with contradictions

- └ Solution 1: CFB Opamp is an exception

Solution 1: CFB Opamp is an exception

Payne 96: The architecture of this device comprises a transresistance op-amp (CCVS) with an additional input voltage-follower (VF)

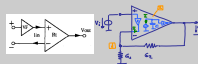

Hitchhiker's guide to the galaxy: "Do you have a solution?"—"No, but I have a different name for the problem."

- Turn the contradiction into an exception
- Cascade of two controlled sources: VCVS, CCVS
- Mathematically OK; unrealistic signal flow (real: CCII and VCVS).
- The author dealt with the contradiction. Another one ignored it.

[2/41]

Current-Mode  
Story

HP Schmid

## Introduction

## Creation

Translinear Loop

## Tenacity

Conveyors

CFB Opamps

Universal AE

## Rigidification

Blindness

Contradictions

## Extinction?

Is it better?

Destruction

Vision

## Hindsight

## Conclusions

Thinking Styles

Publications

Cabeza 97:  
starting from Tellegen  
→ controlled sources  
→ CCI circuits.

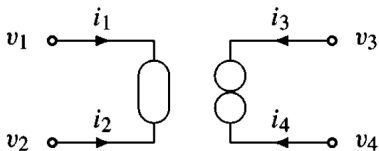

Amplificateur idéal  
(Tellegen)

$$\begin{bmatrix} v_a \\ i_a \end{bmatrix} = \begin{bmatrix} 0 & 0 \\ 0 & 0 \end{bmatrix} \cdot \begin{bmatrix} v_b \\ -i_b \end{bmatrix}$$

## Current-Mode Story

Rigidification

Dealing with contradictions

Solution 2: CFB Opamp is **no** exception

Gabeza 97:  
 starting from Tellegen  
 → controlled sources  
 → CCI circuits.

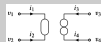
Amplificateur idéal  
(Tellegen)

$$\begin{bmatrix} v_a \\ v_b \end{bmatrix} = \begin{bmatrix} 0 & 0 \\ 0 & 0 \end{bmatrix} \begin{bmatrix} i_a \\ i_b \end{bmatrix}$$

## Nullor again

- Plan: to express the four CS with Nullors
- implement with CCIs.
- Nullor circuits: look at the impedances
- (c) is the CCVS
- CCI: impedances again: something fundamental changed!
- (c) is now the CFB opamp.
- All of them are fine researchers
- locked in thinking style!
- How can we deal with this hurtful thinking constraint?

Nullor equivalent circuits of the four controlled sources:

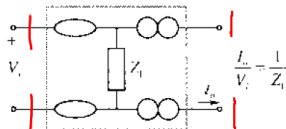
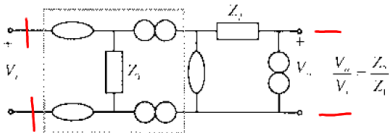

(a)

(b)

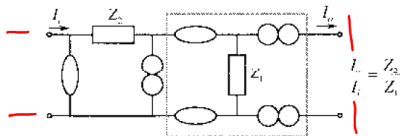
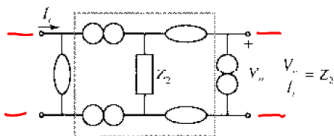

(c)

(d)

## Second-Generation Current-Conveyor (CCII) circuits:

HP Schmid

Introduction

Creation

Translinear Loop

Tenacity

Conveyors

CFB Opamps

Universal AE

Rigidification

Blindness

Contradictions

Extinction?

Is it better?

Destruction

Vision

Hindsight

Conclusions

Thinking Styles

Publications

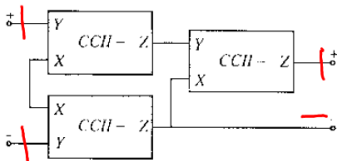

(a)

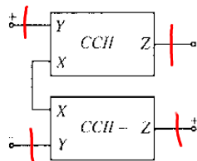

(b)

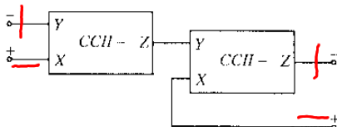

(c)

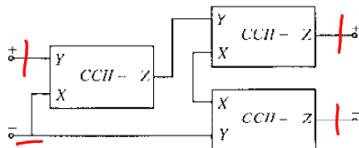

(d)

Current-Mode Story

HP Schmid

Introduction

Creation

Translinear Loop

Tenacity

Conveyors

CFB Opamps

Universal AE

Rigidification

Blindness

Contradictions

Extinction?

Is it better?

Destruction

Vision

Hindsight

Conclusions

Thinking Styles

Publications

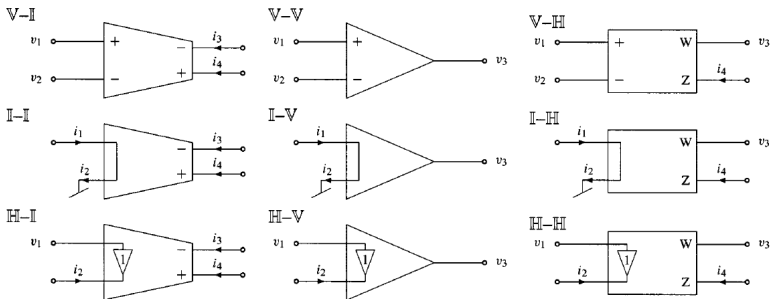

Class	Gain Equation	Operational for	Common Name
V-I	$i_3 = g_m(v_1 - v_2)$	$g_m R_{in} \rightarrow \infty$	operational transconductance amplifier (OTA)
V-V	$v_3 = A_v(v_1 - v_2)$	$A_v \rightarrow \infty$	operational amplifier (opamp)
V-HI	$v_3 = A_v(v_1 - v_2)$	$A_v \rightarrow \infty$	floating opamp (operational floating amplifier, OFA)
I-I	$i_3 = A_i i_1$	$A_i \rightarrow \infty$	current-mode opamp
I-V	$v_3 = r_m i_1$	$r_m / R_{in} \rightarrow \infty$	operational transresistance amplifier (OTRA)
I-HI	$v_3 = r_m i_1$	$r_m / R_{in} \rightarrow \infty$	floating OTRA
H-I	$i_3 = A_i i_2$	$A_i \rightarrow \infty$	current-feedback OTA (CFB OTA) <sup>†</sup>
H-V	$v_3 = r_m i_2$	$r_m / R_{in} \rightarrow \infty$	current-feedback opamp (CFB opamp)
H-HI	$v_3 = r_m i_2$	$r_m / R_{in} \rightarrow \infty$	operational floating conveyor (OFC)

<sup>†</sup> THIS NAME IS PROPOSED BY US

## Current-Mode Story

Rigidification

Dealing with contradictions

Solution 3: Get over thinking constraints

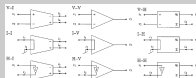

Name	Short Equation	Observed by	Common Name
V=0	$v_i = v_o$	W. S. Kopp	operational transconductance amplifier (OTA)
V=1	$v_i = v_o + 1$	A. S. Sedra	operational amplifier (opamp)
V=0	$v_i = v_o$	A. S. Sedra	buffer (unity-gain) operational transconductance amplifier (OTCA)
V=1	$v_i = v_o + 1$	A. S. Sedra	operational transconductance amplifier (OTCA)
V=0	$v_i = v_o$	A. S. Sedra	buffer (unity-gain) operational transconductance amplifier (OTCA)
V=1	$v_i = v_o + 1$	A. S. Sedra	operational transconductance amplifier (OTCA)
V=0	$v_i = v_o$	A. S. Sedra	buffer (unity-gain) operational transconductance amplifier (OTCA)
V=1	$v_i = v_o + 1$	A. S. Sedra	operational transconductance amplifier (OTCA)
V=0	$v_i = v_o$	A. S. Sedra	buffer (unity-gain) operational transconductance amplifier (OTCA)
V=1	$v_i = v_o + 1$	A. S. Sedra	operational transconductance amplifier (OTCA)

Very simple: dump two-ports, use four-terminals

– input can have low, high, or mixed impedances

– output too

– so we now have *nine* amplifiers!

→ difficult to sell (out of style)

→ writing story ...

– The question “is it really better” arose ...

[2/46]

[Mahattanakul 98]

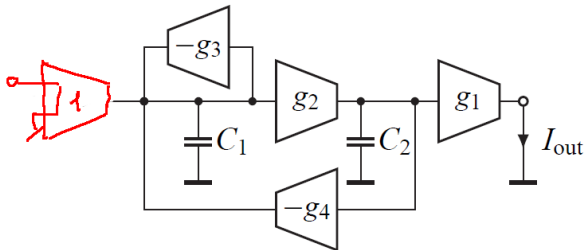
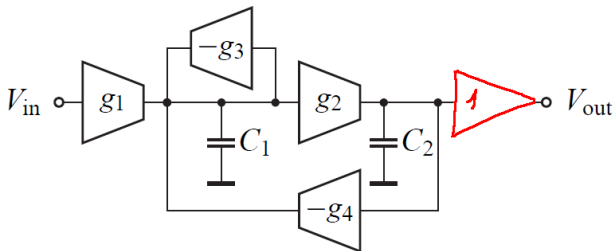

## Current-Mode Story

Extinction?

Now: which one is better?

Thorough comparison for one filter

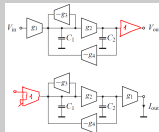
*(Slide timing!)*I know of *only one* thorough comparison:

- Gm–C biquad: Noise, distortion, . . .
- VM slightly outperforms CM because all noise shaped
- However: on a real chip, pads could not be connected directly
- Now both would be the same.
- The only existing thorough comparison shows no difference!
- This being clear, attempts to extinguish CM were made. [2/48]

Current-Mode  
Story

HP Schmid

## Introduction

## Creation

Translinear Loop

## Tenacity

Conveyors

CFB Opamps

Universal AE

## Rigidification

Blindness

Contradictions

## Extinction?

Is it better?

Destruction

Vision

## Hindsight

## Conclusions

Thinking Styles

Publications

Schmid 03: “Why ‘Current Mode’ Does Not Guarantee Good Performance” (invited after an ISCAS talk in **May 2002**)

- Definitions: different ones are in use.
- Technical: no advantage proven or provable.
- Philosophical: how vision became propaganda, and why some findings of the CM community are very valuable.
- Action: attempted **de**construction of the term “current-mode” by showing that it is empty of inherent meaning and only has meaning in the **context** of science as a social process.

Gilbert 04: “Current Mode, Voltage Mode, or Free Mode? A Few Sage Suggestions” (received **June 2002**)

- Definitions: no rigorous definition can be found in literature.
- Technical: no compelling advantages.
- Philosophical: real-world product development requires a “free mode” view, but only as a mnemonic, not a classification.
- Action: attempted **re**construction of the term “current-mode” by narrowing it down so far that it is rather precise (but of limited use); reference to the **context** of everyday life.

# Current-Mode Story

Extinction?

Attempts to break open the thinking style

Two attempts to extinguish current mode

Schmid 03: "Why 'Current Mode' Does Not Guarantee Good Performance" (invited after an ISCAS talk in **May 2002**)

- Definitions: different ones are in use.
- Technical: no advantage proven or provable.
- Philosophical: how "reason" became propaganda, and why some findings of the CM community are very valuable.
- Action: attempted **de**construction of the term "current mode" by showing that it is empty of inherent meaning and only has meaning in the **context** of science as a social process.

Gilbert 04: "Current Mode, Voltage Mode, or Free Mode? A Few Sage Suggestions" (received **June 2002**)

- Definitions: no rigorous definition can be found in literature.
- Technical: no compelling advantages.
- Philosophical: real-world product development requires a "free mode" view, but only as a mnemonic, not a classification.
- Action: attempted **re**construction of the term "current mode" by narrowing it down so far that it is rather precise (but of limited use); reference to the **context** of everyday life.

## Two direct attacks

- both very similar
- both developed in 2001/2002
- I was faster because it was an invited paper after ISCAS2002
- 150 attendants
- “are we not allowed to use ‘current-mode’ anymore?”
- Nevertheless, in 2010, propaganda still endures.

Current-Mode  
Story

HP Schmid

## Introduction

## Creation

Translinear Loop

## Tenacity

Conveyors

CFB Opamps

Universal AE

## Rigidification

Blindness

Contradictions

## Extinction?

Is it better?

Destruction

Vision

## Hindsight

## Conclusions

Thinking Styles

Publications

## Vision:

- higher bandwidth
- simpler architecture
- better dynamic range
- operates at lower voltage
- better linearity
- lower power consumption

## Reality:

- less feedback
- simpler circuits
- wilder ideas
- lower focus on tradition
- different “second-order” problems

## Current-Mode Story

└ Extinction?

└└ What is behind the vision?

└└└ What is behind the vision?

What is behind the vision?

Vision:

- higher bandwidth
- simpler architecture
- better dynamic range
- operates at lower voltage
- better linearity
- lower power consumption

Reality:

- less feedback
- simpler circuits
- wilder ideas
- lower focus on tradition
- different "second-order" problems

Back to the start: the six most recent papers say . . .

– Current-mode reality is . . .

→ Most decisive: different “second-order” problems

– There are also VM circuits doing this

[1/52]

... also exist in the traditional literature; e.g. Nauta 92:

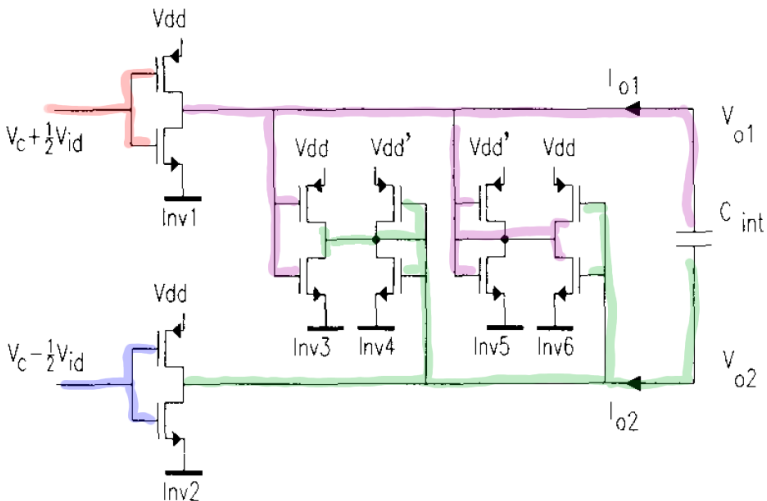

## Current-Mode Story

Extinction?

What is behind the vision?

Very fast and simple circuits

... also exist in the traditional literature; e.g. Nauta 92:

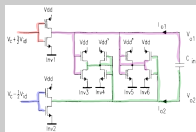
*(Slide timing!)*100-MHz Gm–C filter in  $3\mu$  CMOS!

- Really funny: draw as inverters, show to a digital guy
- enjoy the clash of thinking styles!
- This circuit has no internal nodes!
- Needs controlled  $V_{dd}$

What remains today:

- valuable ideas, already absorbed by the IC designers
- propaganda.
- Was it all a scam? Should it have been prevented? No!
- Don't forget the researcher in the mist!

## Current-Mode Story

HP Schmid

## Introduction

## Creation

Translinear Loop

## Tenacity

Conveyors

CFB Opamps

Universal AE

## Rigidification

Blindness

Contradictions

## Extinction?

Is it better?

Destruction

Vision

## Hindsight

## Conclusions

Thinking Styles

Publications



## Current-Mode Story

└─ Stuck in Style and Hindsight

└─ Stuck in Style: A Tilt-Chip Tale



## Tell the tilt-chip tale

- Even a theory that you know can't be right may work  
→ for some time!
- Just don't forget: mind=parachute.
- Let's conclude this tale with three more slides. . .

Current-Mode  
Story

HP Schmid

## Introduction

## Creation

Translinear Loop

## Tenacity

Conveyors

CFB Opamps

Universal AE

## Rigidification

Blindness

Contradictions

## Extinction?

Is it better?

Destruction

Vision

## Hindsight

## Conclusions

Thinking Styles

Publications

- Facts<sup>1</sup> are **made** by **deliberately** introducing thinking constraints to make things simpler.
- Therefore facts appear, change, and disappear again.
- Facts: elements of style as well as models of reality.
- To publish, “in style” is more important than “true”.
- The only thing that keeps style and reality correlated is a social feedback process in a scientific community.
- Ken Wilber (cited in [Schmid 03]): All that is empirical science has three things in common: a practical injunction (*if you want to know this, you have to do this*); an apprehension, illumination, or experience (*if you do this, you see this*), and communal checking (*did others who did this also see the same?*).

---

<sup>1</sup>lat. *facere* = make/build/construct/create/cause/do

## Current-Mode Story

## └─ Conclusions

## └─ Thinking Styles (after Ludwik Fleck)

## └─ Thinking Styles (after Fleck 35)

- Facts<sup>1</sup> are *made* by *deliberately* introducing thinking constraints to make things simpler.
- Therefore facts appear, change, and disappear again.
- Facts: elements of style as well as models of reality.
- To publish, "in style" is more important than "true".
- The only thing that keeps style and reality correlated is a social feedback process in a scientific community.
- Ken Wilber (quoted in [Schmid 03]): All that is empirical science has three things in common: a practical injunction (*if you want to know this, you have to do this*) an apprehension, illumination, or experience (*if you do this, you see this*), and communal checking (*did others who did this also see the same?*).

<sup>1</sup>lat. *facere* = make/build/construct/create/cause/ido

Matrix Revolutions: "Everything that has a beginning has an end."

– We do not discover facts, we make them!

→ All facts will eventually be un-made.

– If this is true, then even scientists have a wrong idea about science.

How can this be? Because of what we read!

[4/63]

Current-Mode  
Story

HP Schmid

## Introduction

## Creation

Translinear Loop

## Tenacity

Conveyors

CFB Opamps

Universal AE

## Rigidification

Blindness

Contradictions

## Extinction?

Is it better?

Destruction

Vision

## Hindsight

## Conclusions

Thinking Styles

Publications

- 1 Lab journals; written communication with colleagues
- 2 Conference papers
- 3 Journal papers
- 4 Handbooks (for experts)
- 5 Textbooks (for students)
- 6 Popular-science articles and books

## Now ask yourself:

- What have you read in your particular field?
- What have you read about the stuff the other group is doing?
- What have you read about string theory, evolution biology, neuropsychology, geodesy, limnology?

# Current-Mode Story

## Conclusions

### Different types of publications

#### Publications and style development

#### Publications and style development

- 1 Lab journals; written communication with colleagues
- 2 Conference papers
- 3 Journal papers
- 4 Handbooks (for experts)
- 5 Textbooks (for students)
- 6 Popular-science articles and books

#### Now ask yourself:

- What have you read in your particular field?
- What have you read about the stuff the other group is doing?
- What have you read about string theory, evolution biology, neuropsychology, geodesy, limnology?

The further down, the simpler, more logical . . . and further away from reality, both with facts and descriptions how the facts were obtained.

→ So get more confident: “die andern kochen auch nur mit **Wasser**”

[3/66]

Current-Mode  
Story

HP Schmid

## Introduction

## Creation

Translinear Loop

## Tenacity

Conveyors

CFB Opamps

Universal AE

## Rigidification

Blindness

Contradictions

## Extinction?

Is it better?

Destruction

Vision

## Hindsight

## Conclusions

Thinking Styles

Publications

- “Current-mode” is not a matter of having voltages and currents in a circuit: there are always both!
- “Current-mode” is not a matter of using some transistor circuits rather than others: circuits are just tools.
- “Current-mode” is not a matter of using less feedback, nor of simpler circuits: has been done everywhere.
- “Current-mode” is not even a matter of current-in current-out: currents and voltages are not even interesting! (e.g., FM radio is electromagnetic-wave-in sound-wave-out).

“Current mode” is simply a thinking style in which a group of people have made their own facts.

And so it is for every research topic.

2011-02-28

## Current-Mode Story

### Conclusions

#### Different types of publications

### Conclusions

#### Conclusions

- "Current-mode" is not a matter of having voltages and currents in a circuit: there are always both!
- "Current-mode" is not a matter of using some transistor circuits rather than others: circuits are just tools.
- "Current-mode" is not a matter of using less feedback, nor of simpler circuits: has been done everywhere.
- "Current-mode" is not even a matter of current-in current-out: currents and voltages are not even interesting! (e.g., FM radio is electromagnetic-wave-in sound-wave-out).

"Current mode" is simply a thinking style in which a group of people have made their own facts.

*And so it is for every research topic.*

Questions?

[2/68]

Current-Mode  
Story

HP Schmid

**Fleck 35** Ludwik Fleck, *Entstehung und Entwicklung einer wissenschaftlichen Tatsache—Einführung in die Lehre vom Denkstil und Denkkollektiv*. B. Schwabe Verlagbuchhandlung, Basel, 1935.

**Fleck 77** Ludwik Fleck, *Genesis and Development of a Scientific Fact*. University of Chicago Press, 1977.

## Introduction

**Roberts 89** Gordon Roberts and Adel Sedra, "All current-mode frequency selective circuits." *Electronics Letters*, vol. 25(12), pp. 759–761, 1989.

## Creation

Translinear Loop

**Toumazou 90** C. Toumazou, F. Lidgey, and D. G. Haigh, *Analog IC design: The current-mode approach*, Peter Peregrinus Ltd., London, 1990.

## Tenacity

Conveyors

CFB Opamps

Universal AE

**Nauta 92** Bram Nauta, "A CMOS transconductance–C filter technique for very high frequencies." *IEEE Journal of Solid-State Circuits*, vol. 27, pp. 142–153, 1992.

**Payne 96** Alison Payne (now Burdett) and Chris Toumazou, Analog amplifiers: Classification and generalization," *IEEE Transactions on Circuits and Systems I*, vol. 43, pp. 43–50, 1996.

## Rigidification

Blindness

Contradictions

**Cabeza 97** Rafael Cabeza and Alfonso Carlosena, "Analog universal active device: Theory, design and applications," *Analog Integrated Circuits and Signal Processing*, vol. 12, pp. 153–168, 1997.

## Extinction?

Is it better?

Destruction

Vision

**Mahattanakul 98** Jirayuth Mahattanakul and Chris Toumazou, "Current-mode versus voltage-mode Gm-C biquad filters: what the theory says." *IEEE Transactions on Circuits and Systems II: Analog and Digital Signal Processing*, vol 45, pp. 173–186, 1998.

**Schmid 00** Hanspeter Schmid, "Approximating the Universal Active Element," *IEEE Transactions on Circuits and Systems II: Analog and Digital Signal Processing*, vol. 47, pp. 1160–1169, 2000.

## Conclusions

Thinking Styles

Publications

**Schmid 03** Hanspeter Schmid, "Why 'Current-Mode' Does Not Guarantee Good Performance," *Analog Integrated Circuits and Signal Processing*, vol. 37, pp. 79–90, 2004.

**Gilbert 04** Barrie Gilbert, "Current Mode, Voltage Mode, or Free Mode? A Few Sage Suggestions," *Analog Integrated Circuits and Signal Processing*, vol. 38, pp. 83–101, 2004.

Current-Mode  
Story

Excerpts from the first six papers on **IEEE**Xplore on "current-mode filters" in a quick literature search done in December 2010:

HP Schmid

Laoudias (Melecon 2010): Current-mode signal processing is a very promising technique for achieving higher maximum frequency of operation and reduced circuitry compared with those offered by the conventional opamp configurations. Thus, a number of appropriate active blocks have been employed for realizing the corresponding topologies [Toumazou90]

## Introduction

## Creation

Translinear Loop

## Tenacity

Conveyors

CFB Opamps

Universal AE

Li 2010 (Wireless Communications, Networking and Information Security (WCNIS)): And the current-mode universal filter has been more popular than the voltage mode type due to requirements in low-voltage environments such as portable and battery-power equipments. The current-mode technique is more ideally suited to the environment than the voltage-mode variety. For the potential advantage of the current-mode circuits have, such as larger dynamic range, higher signal bandwidth, greater linearity, simpler circuitry, and lower power consumption [Toumazou90], it becoming more popular in recent years.

## Rigidification

Blindness

Contradictions

Kamat (IET Circuits, Devices and Systems, 2010): At present there is growing interest in current-mode signal processing [Toumazou90] because of its advantages like increased bandwidth, high dynamic range and reduced power supply requirements.

## Extinction?

Is it better?

Destruction

Vision

Imran (ARTcom 2010): In the last decade, one has seen the growth of the prominence of the current mode circuits. Current mode circuits exhibit reliable high frequency response, have simpler architecture, provides better dynamic ranges and operate at lower voltages than their VM counterparts. Current Conveyor introduced in 1968 by Sedra and Smith is a versatile building block.. In the literature many modified versions of the current conveyor exist like for example DVCCII, ICCII, FDCCII, DOCCII and many others. [no reference!]

## Hindsight

Zhao (ICASSP 2010): It is well known that current-mode circuits can offer many advantages, such as simplicity of circuit structure, high-frequency operation, wide dynamic range, and so on, compared with their voltage-mode counterpart [no reference!]

## Conclusions

Thinking Styles

Publications

Kumngern (ECTI-CON 2010): At present, the design and implementation of current-mode active filters using second-generation current conveyors (CCII) have received considerable attention owing to the fact that their bandwidth, linearity, simple circuitry, low power consumption and dynamic range performances are better than those of their operational amplifier (op-amp) based counterparts [Roberts89]